

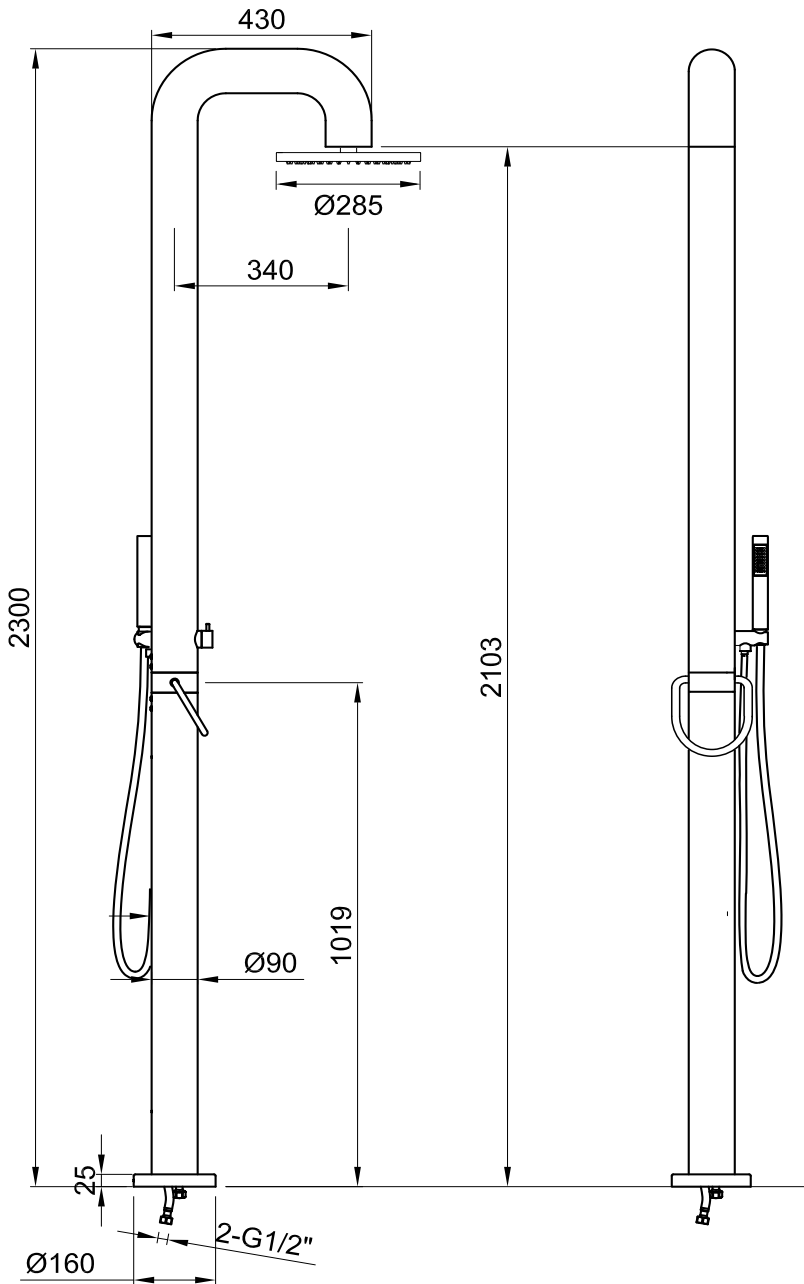

JEE-O fatline shower 02



fatline interchangeable showerhead 85 and 285 included



middle down - off

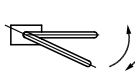

down - waterflow off

up - waterflow on

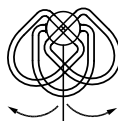

left - hot

right - cold

Article code:

200-6210

Brushed

Material:

Stainless Steel r316

Cleaning instructions:

download JEE-O shower and taps manual on our website: www.jee-o.com

Cartridges:

Kerox ceramic mixing mechanism (40mm), item code 005-0102 and JEE-O ceramic diverter mechanism, item code 005-0302

Interchangeable shower heads

Ø285mm/127 nozzles, item code 201-6140
Ø85mm/ 78 nozzles, item code 201-6120

Flow at water of 38°C:

12l p/m at 3Bar pressure

Pressure:

Recommended working pressure 3Bar

Flexhose:

150 cm length

Connection:

2 x G 1/2" (Ø15mm / 0.6")
nylon^(out)/epdm⁽ⁱⁿ⁾ flexhose
with stainless steel swivel
British Standard Pipe (BSP)

Thread:

Dimension package:

L 161 x W 27 W 66 x H 24 cm

Total weight

18,7 kg

Package weight:

3,2 kg

Placing on a water-tight floor

7 year warranty - The general conditions can be found on our website: www.jee-o.com/downloads

HS code:

84818011900

Approvals:

SLS BS EN 817, SS 375,
AS/NZS 4020, BS EN



JEE-O fatline shower 02 specifications | February 2024

Models are subject to change and specs may contain typographical errors

Slight variations in the aesthetic appearance of the product, including the color, may occur after exposure to external influences such as sunlight, pollution or harmful chemicals